

Lunar Landing Payload Crane

Team 517 | Alanna Black | Jayson Dickinson | Christina Morrow | Ryker Mullinix

OBJECTIVE

The objective of this project is to offload the LSMS (Lightweight Surface Manipulation System) from the lunar lander onto a platform on the lunar surface.

ARROW

AUTOMATED AND RANGED RELOCATION OF THE LSMS FOR WIDER APPLICATION

Detail A

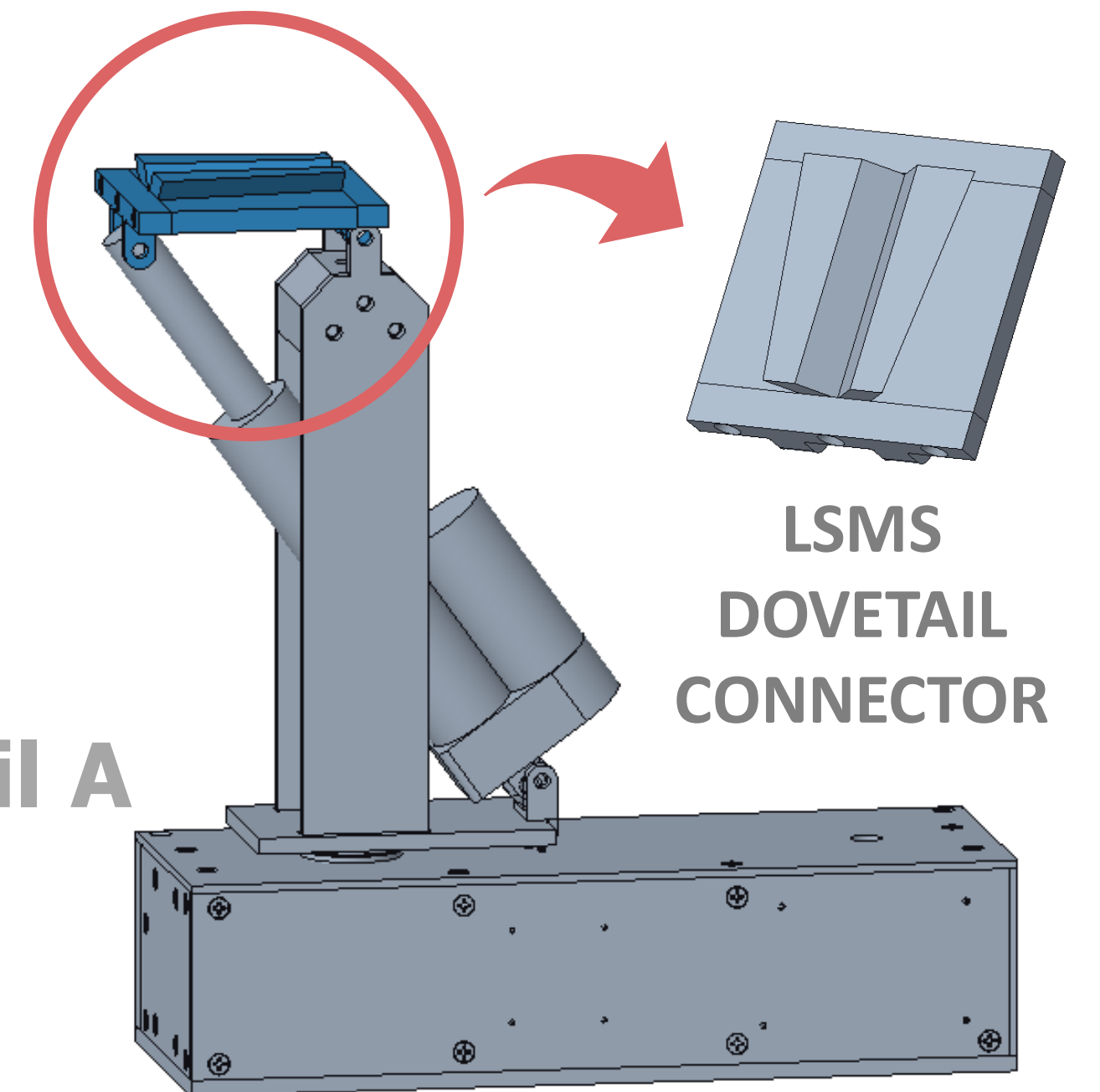

ARTEMIS

Artemis is the goddess of the Hunt; her symbols are the bow and arrow.

DESIGN

STEP 1: SPIN the LSMS

We need to rotate the base of the LSMS off the lander deck.

- LINEAR ACTUATOR
- RACK & PINION
- TURNTABLE

Rotates 90°

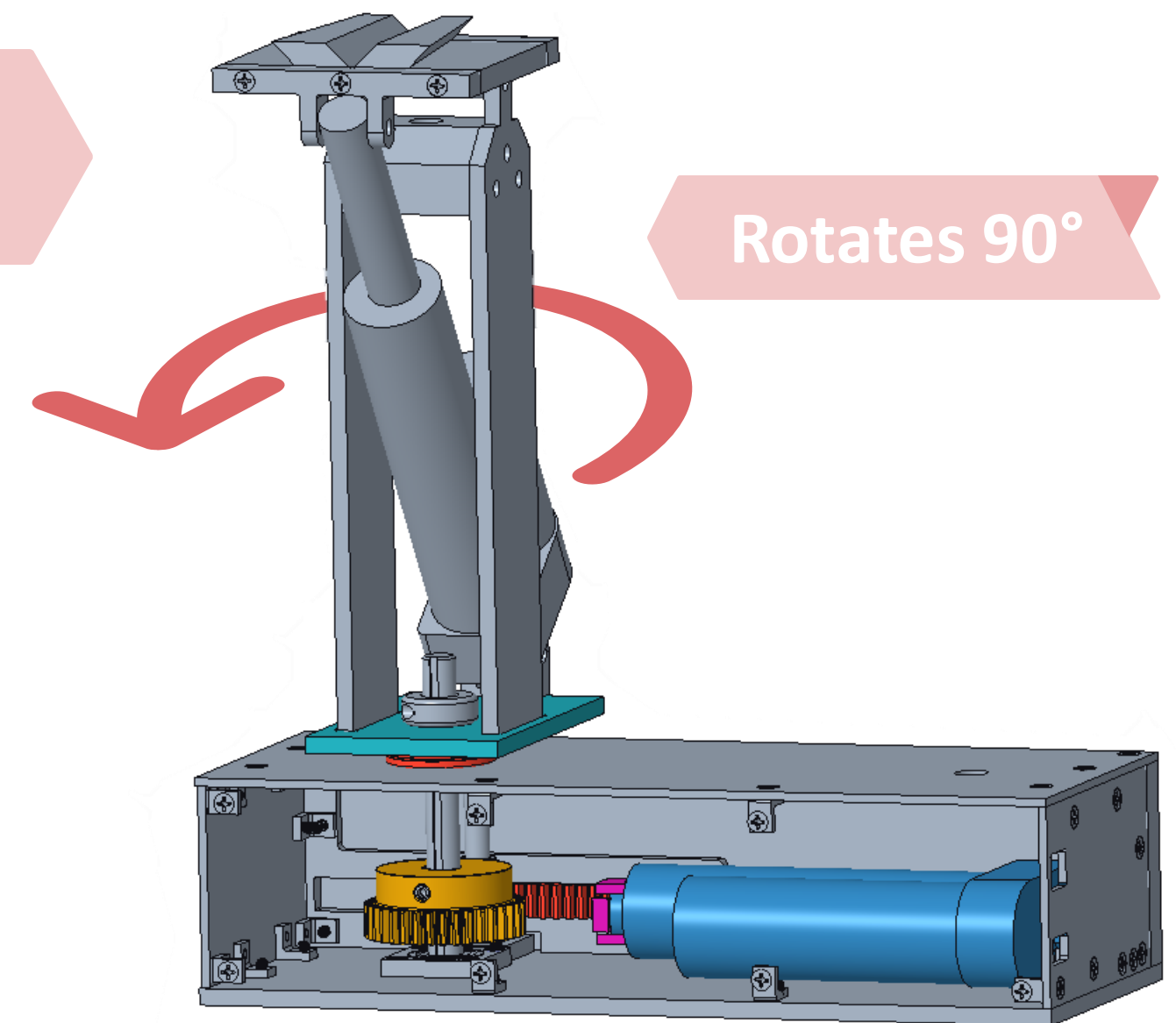

STEP 2: LOWER the LSMS

We need to lower the LSMS onto the platform.

- LINEAR ACTUATOR
- CONNECTOR PLATE

Pivots 44°

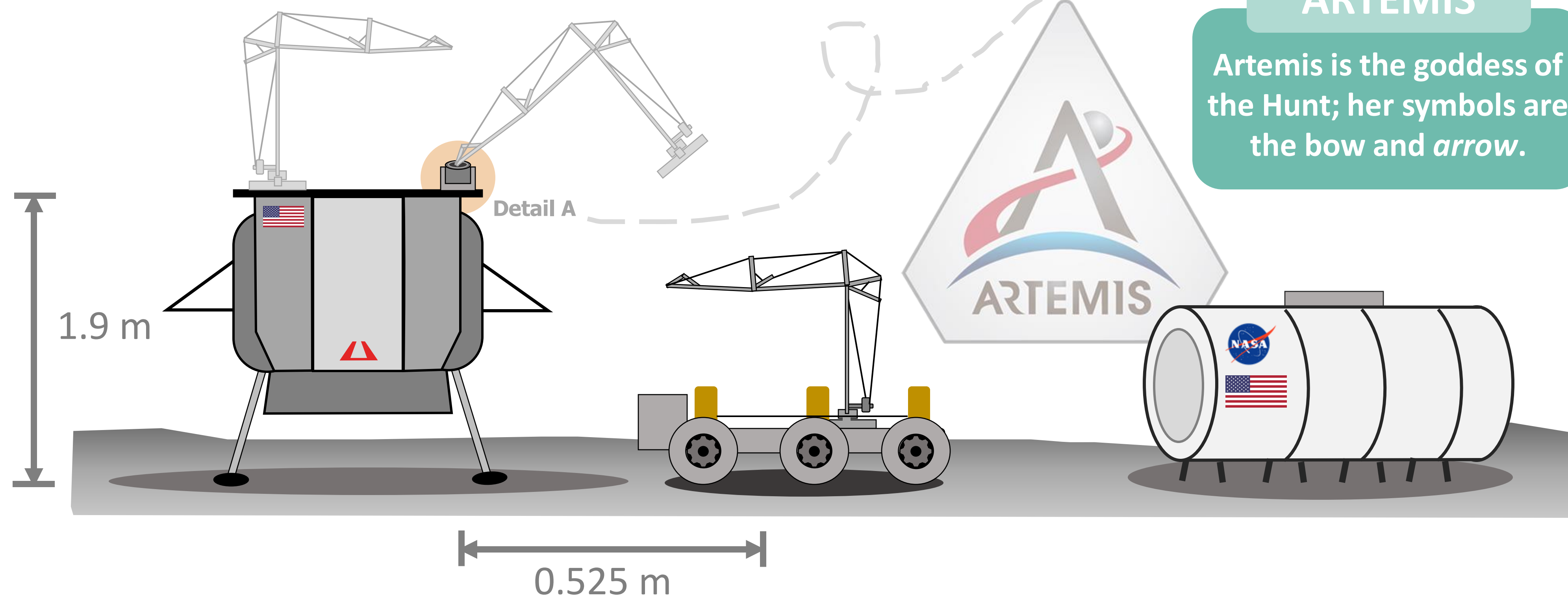
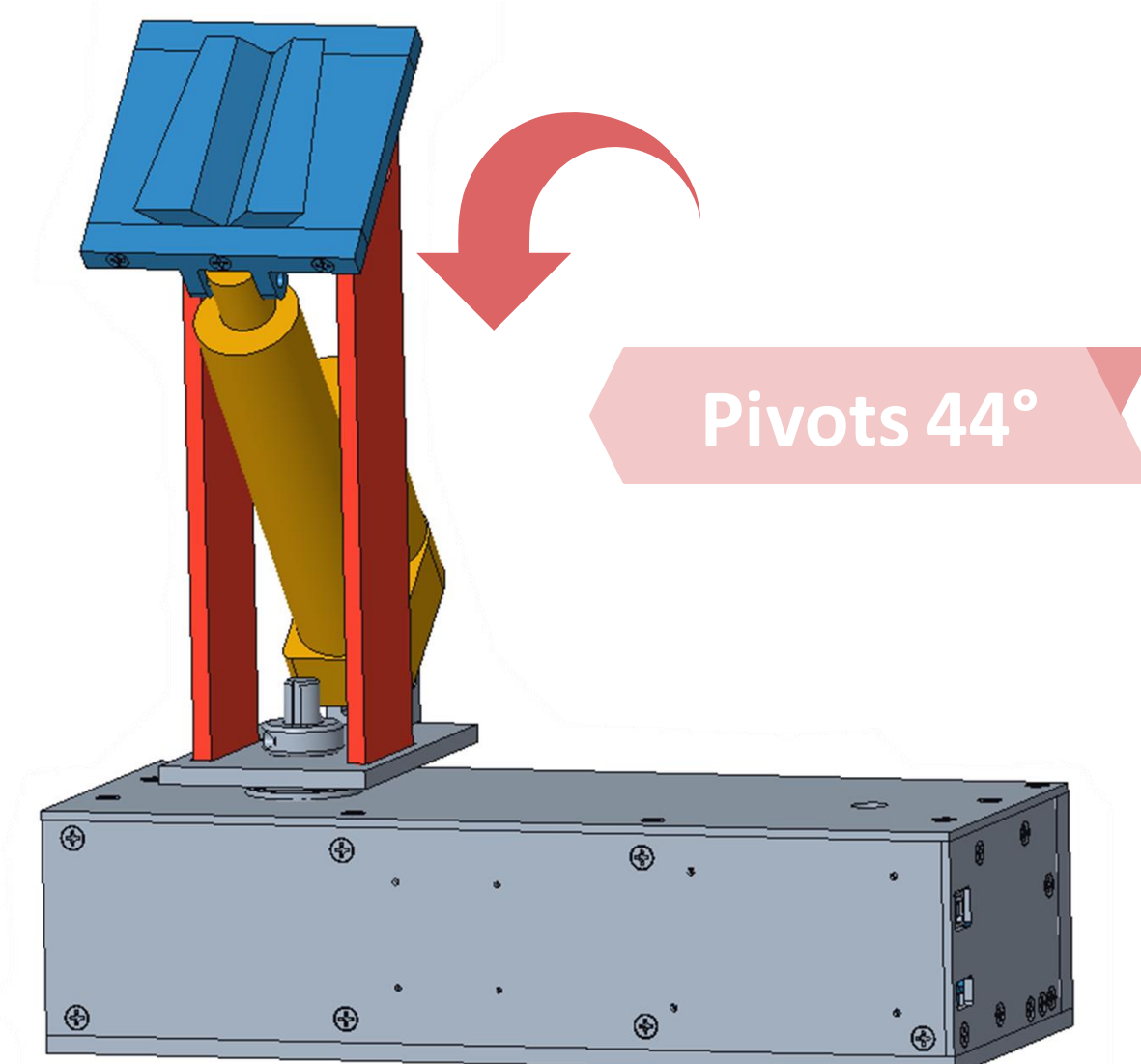

KEY GOALS

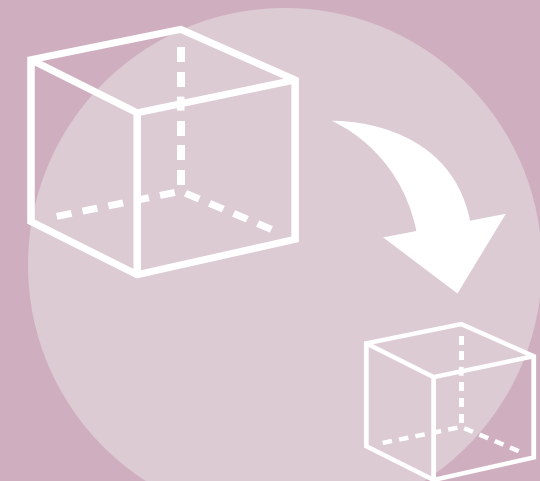

Scalable

20 LBS

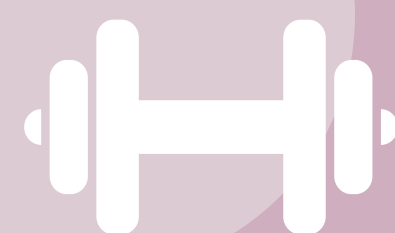

Weight

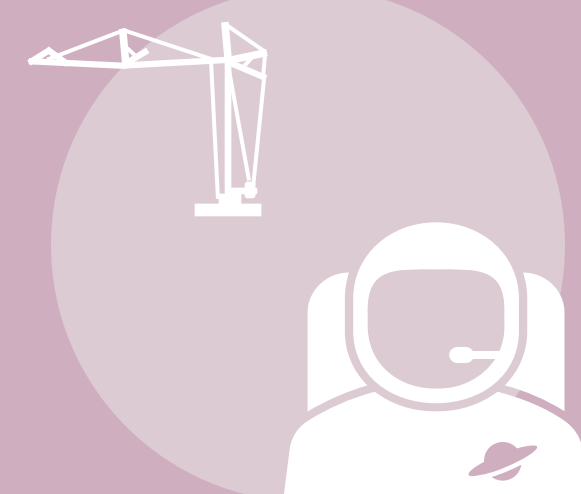

Autonomy

VALIDATION

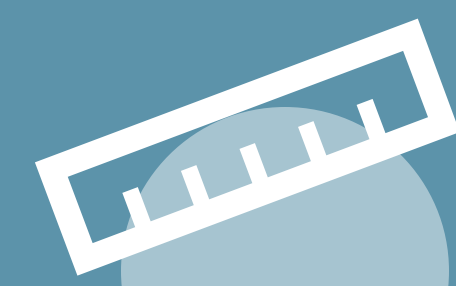

2.26%

Motion

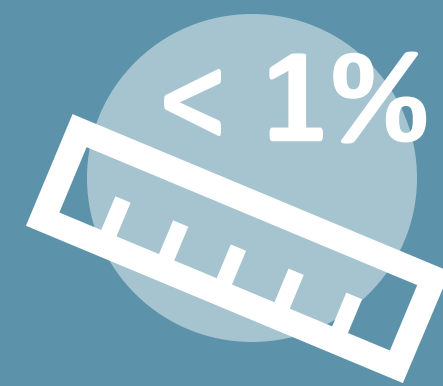

< 1%

Support

0.26%



Power



5%

Communicate